

Hydraulischer Kraftaufnehmer Modell HKMD29 D

Hydraulic Force Gauge Model HKMD29 D



Beschreibung	Description
<p>Hydraulische Kraftaufnehmer/ Kraftmessdosen, arbeiten nach dem Prinzip, dass die auf den Kolben wirkende Kraft – entsprechend der Kolbenfläche – in einen hydraulischen Druck umgewandelt wird und über das Messorgan, analog, als Krafteinheit skaliert, angezeigt wird.</p> <p>Messsysteme dieser Art sind für statischen bzw. quasistatischen Einsatz bestens geeignet. Durch die Unabhängigkeit von einer Stromquelle bieten sie für unterschiedliche Anwendungsbereiche ideale Einsatzgebiete (so z.B. in der Luft- und Raumfahrt).</p> <p>Die Kraftanstiegs- und Abfallzeit sollte mindestens 0,5 s betragen, eventuell bei der Be- oder Entlastung auftretende Schläge können jedoch mit speziellen Drosseln gedämpft werden (Option).</p> <p>Das Gehäuse des HKMD29 D muss ganzflächig aufliegen, der pendelnde Kolben gleicht Unebenheiten bis max. 3° aus.</p>	<p>Hydraulic force gauges working according the principle, that the force effective on the piston is converted into a hydraulic pressure, whereby the analogue result is displayed on a dial gauge, scaled in a force value.</p> <p>Systems working on the hydraulic principle are used for static or quasi- static applications. Especially in view of independence of a voltage supply, it can be used in a wide range of applications (e.g. aerospace industry).</p> <p>The increasing and decreasing time of the force has to be min. 0.5 sec. peaks occurring during loading or relief can, however, be damped with special chokes (Optional).</p> <p>The housing of the HKMD29 D should fit over the entire area, whereby the piston compensates unevenness up to 3°.</p>

Wesentliche Merkmale	Characteristics
Messbereiche von 250 N... 630 kN	Measuring ranges from 250 N up to 630 kN
Anzeigebereich 10 ... 100% v.E.	Display range 10 ... 100% f.s.
Messgenauigkeit $\leq \pm 1\%$ v.E.	Accuracy $\leq \pm 1\%$ % of end value (f.s.)
Betriebstemperaturbereich: 0 ... 50°C	Service temperature range: 0 ... 50°C
Separate Anzeige für Istwert und Maximalwert	Display for current and max. value
Zur Kontrollmessung von Druckkräften	For checking of compression forces
Vorlast kann tariert werden	Preload could be adjusted
Automatische Displayabschaltung, deaktivierbar	Display auto power off function, can be deactivated

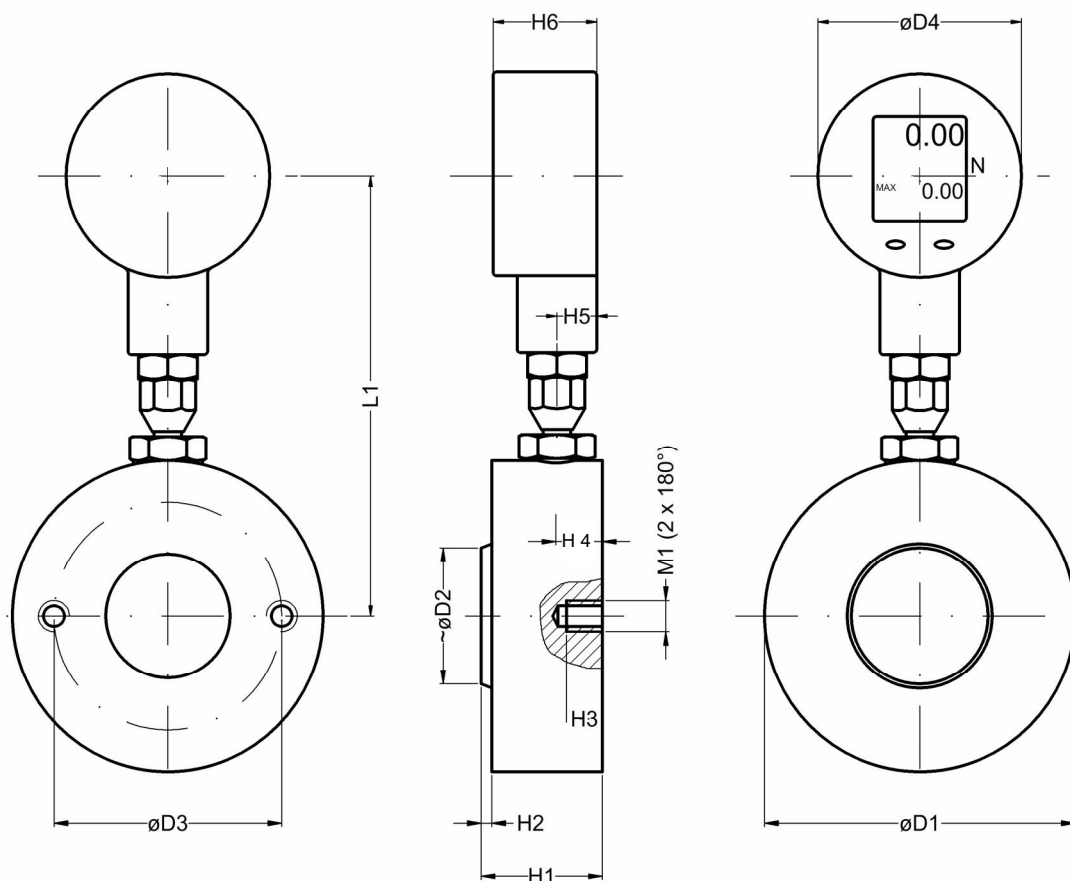

Messbereich / Measuring Range	Baugröße / Size	Bruchlast d. Anzeige / Breaking load dial	Hochdruckschlauch / High pressure hose	Kapillarrohr / Capillary tube	Gewicht / Weight	Abmessungen (mm) / Dimensions (mm)											Anzahl der Gewinde / No. of threads																
						D1	D2	D3	D4	H1	H2	H3	H4	H5	H6	L1		M1															
HKMD 29D			max., in m	kg	D1	D2	D3	D4	H1	H2	H3	H4	H5	H6	L1	M1	M1																
250 N	G0	>1 kN	-	-	1,7	75	34	55	59	30	3	10	14	13	30	120	M6	2															
500 N																																	
1 kN		>6 kN	-	0,5																													
2,5 kN																																	
5 kN				0,5															1														
10 kN			>40 kN																														
25 kN				1															2,5														
50 kN	G1	>75 kN	1	2,5	2	90	55	75	59	32	3	10	14	13	30	128	M8	2															
75 kN																																	
50 kN		>75 kN																															
75 kN		>180 kN																															
100 kN	G2	>300 kN	1	2,5	4,4	145	112	130	59	38	4	10	16	13	30	154	M8	2															
250 kN																																	
400 kN		>700 kN																															
630 kN																																	

... Vorzugs-Messbereiche // Preferential Measuring Ranges

... Andere Baugrößen und Messbereiche sind auf Anfrage lieferbar. // Other ranges and sizes available on request.



Die Kraftmesser HKMD29 D in Baugröße 0 und 1 ohne Zubehör werden in einem Kunststoff-Koffer geliefert.

The hydraulic gauges HKMD29 D size 0 and 1 without accessories will be shipped in a plastic case.