



WEIGHING UNIT PK 1000

ACCESSORIES FOR LOADCELL K350 OCH K1000

WEIGHING UNIT TYPE PK is used in S-E-G weighing systems for weighing small hoppers or platforms.

The weighing unit consists of two vertical members, interconnected by two accurately matched parallel flat springs.

Disturbing forces and torques acting on the load carrier will be taken up by the weighing unit without acting on the load cell.

The mounting holes have the same position on both sides of the unit. To reduce the influence from rough or uneven mounting surfaces, the two lower mounting brackets have been made pliant to rotation around the vertical axis. Fastening must always be done in both upper and lower brackets.

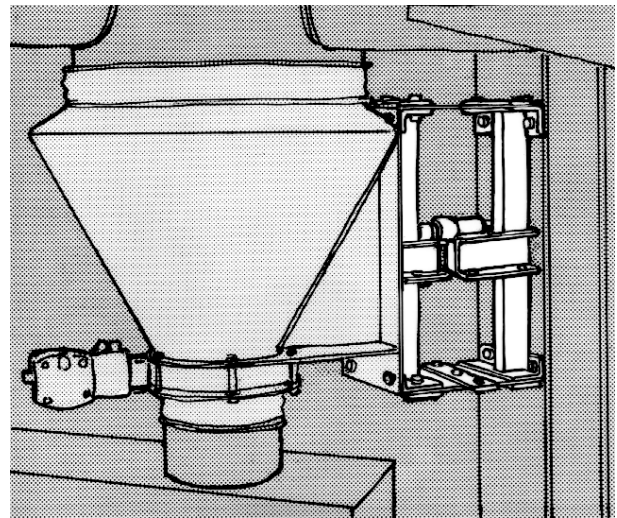

DESIGNATIONS AND SPECIFICATIONS

Designation: PK-1000 Maximum load: 1000 kg.

The centre of gravity of the load must fall within a circle with a max. radius of 500mm around the line of symmetry of the mounting surface. Refer to figure below.

Loadcell K350 or K1000 depending on the actual gross weight. (To be ordered separately)

Coating: Blue enamel on rust resistant primer.

DIMENSIONS AND WEIGHT

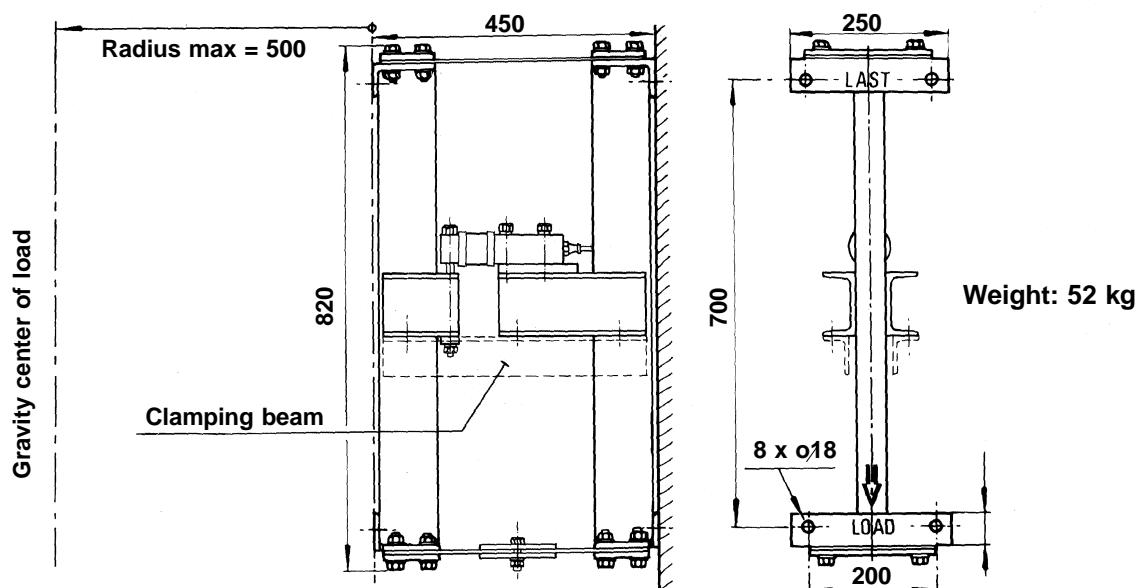

832



Vertrieb, Ersatzteile und Service in Deutschland:
INDUK GmbH • Giebel 30 • D-42327 Wuppertal
 Tel. +49 (0) 202/ 74 99 870 • Fax +49 (0) 202/ 74 99 877
 E-Mail: info@induk.de • Internet: www.induk.de

S-E-G INSTRUMENT AB

Box 111 43, S-161 11 Bromma, SWEDEN
 Phone: (+46) 8 7647400 Fax: (+46) 8 7647500 Internet: www.s-e-g.com
 VAT: SE556186188001